

值得信赖的水泵智能控制器制造商
Trusted water pump intelligent controller manufacturer

SOYUE® 索月
EXPERT IN PRESSURE CONTROL

TAIZHOU SOYUE
ELECTRONIC
TECHNOLOGY
CO.,LTD

SOYUE® 索月

台州索月电子科技有限公司
TAIZHOU SOYUE ELECTRONIC TECHNOLOGY CO.,LTD.

Add: 浙江省台州市椒江区海正大道350号
NO.350HaiZheng Road Jiaojiang Taizhou Zhejiang China
Tel: 86-576-88665858 89069898 Fax: 86-0576-88665959
Email: sales01@china-soyue.com Web: www.china-soyue.com

全国免费服务热线:
400-119-9111



SOYUE®

PRESSURE CONTROL

索月是领先的水泵智能控制器生产商，长期坚持技术与革新相结合。

新一代智能控制器的设计独具匠心，人性化的质控细节，
带给用户方便、安全、高效的用水体验！

soyue is a leading manufacturer of intelligent pump controller,
long-term adherence to the combination of technology and innovation.

A new generation of intelligent controller design originality, user-friendly quality control details,
to give users convenient, safe and efficient water experience!

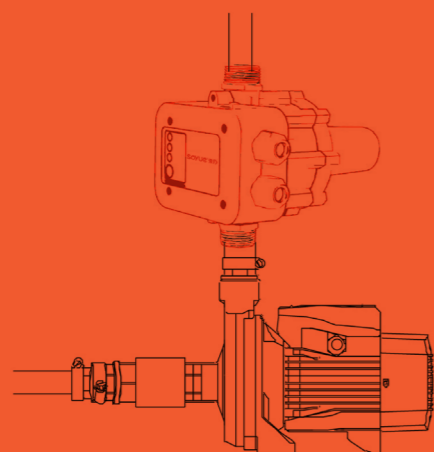

Brief introduction

企业简介

Taizhou Soyue Electronic Technology Co.,Ltd established in 2010, is a leading professional manufacturer for research, development ,production and sales of automatic pressure controls, float switches and accessories for water pump. Our factory is located in the beautiful seaside city, Taizhou ,Zhejiang, with a prosperous economy, convenient transportation and superior environment.

To meet all kinds of needs, we can develop and produce to client's special demand. We have our own 3D designer, mould developing lines, high pressure PU injection machine, PCB machine line and advanced testing equipment, which can be easier for customers to design and develop new products. We achieve the quality management and have received CCC security certification and ISO9001:2008 quality system certification. Our products all successfully meet standards with European CE, TUV, ROHS, and UL Certificates.

Honest strengthens the basis. Innovation leads to the future development! Sincerely welcome all customers to make cooperation with us therefore promote mutual development. Together to create a kind of water environment more intelligent, more environment protective ,more energy-efficient!

台州索月电子科技有限公司成立于2010年，是一家专业研发生产水泵电子压力控制器，液位浮球开关及其它电子电器产品的出口型企业。公司位于经济发达、交通便捷、环境优美、制造业相关配套完善的港湾城市浙江台州。

公司集三维图纸设计、模具研发制造、PCB集成电路开发为一体，引进全新伺服高压注塑机、PCB波峰焊自动生产线等一系列相关生产、检测、测试设备和相关技术团队，确保了公司产品的长期稳定性！公司已经通过ISO9001：2008 质量管理体系认证，CE、TUV、ROHS、UL等产品国际认证标准！为最大限度地满足客户的各种需求，索月可依据客户的要求量身开发及设计生产。

本着“诚信立足”的经营理念，“注重细节”的质量意识，“专注负责”的服务态度，竭诚欢迎各新老客户莅临指导、真诚合作，携手并进，共同技术先进更智能、更环保，更人性化的用水环境！

压力控制器专家

EXPERT IN PRESSURE CONTROL

随着世界工业不断发展，地球可用水资源日益匮乏，为了更好的利用有限的水资源，SOYUC 索月 倡导全人类选择更智能，更环保，更人性化的用水……

With the continuous development of world industry, the available water resources on the earth is keeping decreasing . In order to make the most use of water resources ,SOYUC 索月 advocate all mankind using water more intelligently, more environmentally friendly and in a more humanized way.



家庭用水 Household Water Consumption

微电脑控制系统，更节能、更智能、更人性化！

Microcomputer control system, more energy-saving, more intelligent and more humanized.

商业用水 Commerical Water Consumption

适用于新老楼宇供暖 / 空调 / 用水、更安全、更环保！

Apply to heating supply , air-conditioner and water use of old and new buildings, safer and more environmentally-friendly.

园林用水 Garden Water Consumption

改善水力失衡，延长水泵使用寿命，有效利用水资源！

Improve the imbalance of water conservancy, extend water pump service life, make the most use of water resources.



健康舒适的水环境是我们每个人的追求，我们需要舒适良好的生活用水环境，在自己的家里享受温馨与安宁。

那么，如何提高，改善现代化的用水环境呢？

在这忙碌的城市，我们需要更智能，更环保，更人性化，更舒适的用水环境，

关爱您的每分每秒，SOYUC 索月 一直在您身边……

- 
- 更智能 \ More intelligent
 - 更环保 \ More energy-saving
 - 更人性化 \ More humanized

产品用途 Products Usage

SOYUE 索月 水泵智能压力控制器是一种更人性化的新型智能系统，广泛应用于各种自吸泵、喷射泵、离心泵、花园泵等供水系统的智能控制。

SOYUE 索月 automatic water pump controller is a more humanized and new kind of intelligent control system, being widely used in the intelligent control of water supply system in various self-priming pumps, jet pumps, centrifugal pumps, garden pumps etc

领域创新 Products Advantages

○ 动感外形: Dynamic Shape

流线型设计，释放动态魅力，尽显智能科技。
Streamlined design release dynamic glamour, manifesting intelligent technology.

○ 结构精巧: Delicate structure:

压力腔与智能系统完美搭配，外观美丽精致，体积轻巧，倡导节能环保。
Pressure chamber matches perfectly with intelligent control system, exquisite appearance, compact size, advocating saving energy and protecting the environment.

○ 延时启动: Delay startup:

控制器通电后，会延时3秒启动，以保护水泵及人身安全。
The pressure controller delays to start 3 seconds after the current is switched on to protect the water pump and personnel safety.

○ 缺水保护: Dry running protection:

无水使用3分钟后，控制器会自动切断水泵电源。
After 3 minutes usage without water, the controller will cut off current source automatically.

○ 自动重启: Automatic restart:

分时循环自动重启检测有无水流通过，直至正常供水。
Circulate by time, automatically restart to test water flow until water supply going stable.

○ 止水停机: Stop water supply and stop the machine:

停止用水时，智能控制系统会自动检测到并控制水泵减速停机。
When stopping water supply, the intelligent control system will inspect automatically and control the pump to slow down and stop operating.

○ 流量控制: Flow Control:

当出水口出水量很小时，智控系统会自动侦测并切换到小流量控制系统，保证水泵正常使用，控制器使用寿命无限延长，真正实现了水泵无障碍运转。
When the outlet water flow becomes small, the intelligent control system will inspect automatically and switch to small flow control system to guarantee normal use of the water pump, which infinitely extends the life span of the controller and authentically realize the barrier-free operation of water pump.

○ 卡机保护: Machine Crash Protection:

水泵长时间不使用情况下，每隔72小时会自动运行8秒，以清除污浊水质，防止水泵卡机。
Long-term without operation, the water pump will automatically operate and work for 8 seconds in every 72 hours to clean dirty water to prevent water pump breakdowns.

○ 过载保护: Overload Protection:

智控系统内部配置热过载保护器，防止非正常使用情况下水泵过热烧毁。
The intelligent system is equipped with heat overload protector to prevent water pump being overheated and damages under abnormal use.

PRESSURE SWITCH | PS-01

WWW.CHINA-SOYUE.COM

SOYUE 索月
EXPERT IN PRESSURE CONTROL

PS-01 PRESSURE SWITCH

产品参数 / TECHNICAL DATA

Rated voltage (额定电压): 110V/220V/85V-285V

Maximum current (最大电流): 10A/20A/30A

Frequency (频率): 50/60Hz

Maximum power (最大功率): 1.1kw/1.8kw/2.2kw

Interface thread (接口螺纹): G1"/G1 1/2"/G1 1/4"

Start pressure (启动压力): 1.0Bar/1.5Bar/2.2Bar/1.0-2.5Bar/2.5-4.0Bar

Maximum working pressure (最大工作压力): 10Bar

Protection grade (保护等级): IP65

Maximum operating temperature (最高工作温度): 60°C/100°C

Color (颜色): optional (可选配)

Cable (电线): optional (可选配)

包装尺寸 / PACKING SIZE

Model 型号	Packing 包装	Size 尺寸	G.W/N.W. 毛/净重(KGS)	Loading 装柜量
PS01-1	12pcs/ctn	52 x 47 x 37	17.2/16.2	40ft HQ: 9000pcs, 20ft: 3700
PS01-2A	12pcs/ctn	52 x 47 x 37	17.2/16.2	40ft HQ: 9000pcs, 20ft: 3700
PS01-2B	12pcs/ctn	56 x 47 x 37	17.2/16.2	40ft HQ: 8200pcs, 20ft: 3300
PS01-3	12pcs/ctn	56 x 50.5 x 38	22.2/21.2	40ft HQ: 7500pcs, 20ft: 3000

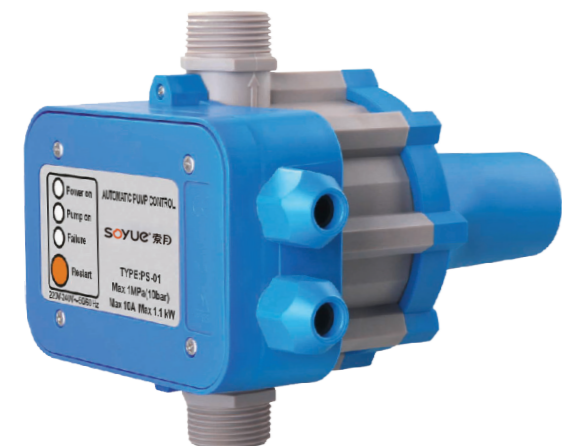

PS01-1



PS01-2A



PS01-2B



PS01-3

HEIGHT ↑↓	PUMP PRESSURE 🔧	START PRESSURE 📏	🔌
10m	2,5Bar	1,5Bar	🔌
20m	4Bar	2,3Bar	🔌
30m	5Bar	3,5Bar	🔌
40m	6Bar	4,5Bar	🔌

PRESSURE SWITCH | PS-02

WWW.CHINA-SOYUE.COM

SOYUE 索月
EXPERT IN PRESSURE CONTROL

PS-02 PRESSURE SWITCH

产品参数 / TECHNICAL DATA

Rated voltage (额定电压): 110V/220V/85V-285V

Maximum current (最大电流): 10A/20A/30A

Frequency (频率): 50/60Hz

Maximum power (最大功率): 1.1kw/1.8kw/2.2kw

Interface thread (接口螺纹): G1"/G2"

Start pressure (启动压力): 1.0Bar/1.5Bar/2.2Bar/1.0-2.5Bar/2.5-4.0Bar

Maximum working pressure (最大工作压力): 10Bar

Protection grade (保护等级): IP65

Maximum operating temperature (最高工作温度): 60°C/100°C

Color (颜色): optional (可选配)

Cable (电线): optional (可选配)



PS02-1A



PS02-1B



PS02-1C



PS02-2A



PS02-2B



PS02-3

包装尺寸 / PACKING SIZE

Model 型号	Packing 包装	Size 尺寸	G.W/N.W. 毛/净重(KGS)	Loading 装柜量
PS02-1A	15pcs/ctn	53 x 47 x 25	16.6/15.6	40ft HQ: 16350pcs, 20ft: 6700
PS02-1B	16pcs/ctn	52 x 47 x 37	19.2/18.2	40ft HQ: 12000pcs, 20ft: 4900
PS02-1C	15pcs/ctn	53 x 47 x 25	16.6/15.6	40ft HQ: 16350pcs, 20ft: 6700
PS02-2A	15pcs/ctn	53 x 47 x 25	16.6/15.6	40ft HQ: 16350pcs, 20ft: 6700
PS02-2B	16pcs/ctn	52 x 47 x 37	19.2/18.2	40ft HQ: 12000pcs, 20ft: 4900
PS02-3	15pcs/ctn	53 x 47 x 25	16.6/15.6	40ft HQ: 16350pcs, 20ft: 6700

HEIGHT ↑↓	PUMP PRESSURE	START PRESSURE	
10m	2,5Bar	1,5Bar	●
20m	4Bar	2,3Bar	●
30m	5Bar	3,5Bar	●
40m	6Bar	4,5Bar	●

PRESSURE SWITCH | PS-03

WWW.CHINA-SOYUE.COM

SOYUE 索月
EXPERT IN PRESSURE CONTROL

PS-03 PRESSURE SWITCH

产品参数 / TECHNICAL DATA

Rated voltage (额定电压): 110V/220V/85V-285V

Maximum current (最大电流): 10A/20A/30A

Frequency (频率): 50/60Hz

Maximum power (最大功率): 1.1kw/1.8kw/2.2kw

Interface thread (接口螺纹): G1"

Start pressure (启动压力): 1.0Bar/1.5Bar/2.2Bar/1.0-2.5Bar/2.5-4.0Bar

Maximum working pressure (最大工作压力): 10Bar

Protection grade (保护等级): IP65

Maximum operating temperature (最高工作温度): 60°C/100°C

Color (颜色): optional (可选配)

Cable (电线): optional (可选配)



PS03-1A



PS03-1B



PS03-1C



PS03-2



OPTIONAL

包装尺寸 / PACKING SIZE

Model 型号	Packing 包装	Size 尺寸	G.W/N.W. 毛/净重(KGS)	Loading 装柜量
PS03-1A	12pcs/ctn	51 x 43 x 28	14.8/13.8	40ft HQ: 13200pcs, 20ft: 5400
PS03-1B	12pcs/ctn	51 x 43 x 28	14.8/13.8	40ft HQ: 13200pcs, 20ft: 5400
PS03-1C	12pcs/ctn	51 x 43 x 28	14.8/13.8	40ft HQ: 13200pcs, 20ft: 5400
PS03-2	12pcs/ctn	51 x 43 x 28	14.8/13.8	40ft HQ: 13200pcs, 20ft: 5400

HEIGHT ↑↓	PUMP PRESSURE 🔧	START PRESSURE 📊	🔌
10m	2,5Bar	1,5Bar	🔌
20m	4Bar	2,3Bar	🔌
30m	5Bar	3,5Bar	🔌
40m	6Bar	4,5Bar	🔌

PRESSURE SWITCH | PS-05

WWW.CHINA-SOYUE.COM

SOYUE 索月
EXPERT IN PRESSURE CONTROL



PS05-1A



OPTIONAL



PS05-1B



OPTIONAL

PS-05 PRESSURE SWITCH

产品参数 / TECHNICAL DATA

Rated voltage (额定电压): 110V/220V/85V-285V

Maximum current (最大电流): 10A/20A/30A

Frequency (频率): 50/60Hz

Maximum power (最大功率): 1.1kw/1.8kw/2.2kw

Interface thread (接口螺纹): G1"

Start pressure (启动压力): 1.0Bar/1.5Bar/2.2Bar/1.0-2.5Bar/2.5-4.0Bar

Maximum working pressure (最大工作压力): 10Bar

Protection grade (保护等级): IP65

Maximum operating temperature (最高工作温度): 60°C/100°C

Color (颜色): optional (可选配)

Cable (电线): optional (可选配)

包装尺寸 / PACKING SIZE

Model 型号	Packing 包装	Size 尺寸	G.W/N.W. 毛/净重(KGS)	Loading 装柜量
PS05-1A	12pcs/ctn	60 x 46.5 x 20.5	15.7/14.7	40ft HQ: 14200pcs, 20ft: 5800
PS05-1B	12pcs/ctn	60 x 46.5 x 24.5	15.7/14.7	40ft HQ: 11900pcs, 20ft: 4800

HEIGHT ↑↓	PUMP PRESSURE 🔧	START PRESSURE 📊	🔌
10m	2,5Bar	1,5Bar	🔌
20m	4Bar	2,3Bar	🔌
30m	5Bar	3,5Bar	🔌
40m	6Bar	4,5Bar	🔌

PRESSURE SWITCH | PS-06

WWW.CHINA-SOYUE.COM

SOYUE 索月
EXPERT IN PRESSURE CONTROL



PS06-1A



PS06-1A



PS06-1A



PS06-1B

PS-06 PRESSURE SWITCH

产品参数 / TECHNICAL DATA

Rated voltage (额定电压): 110V/220V/85V-285V

Maximum current (最大电流): 10A/20A/30A

Frequency (频率): 50/60Hz

Maximum power (最大功率): 1.1kw/1.8kw/2.2kw

Interface thread (接口螺纹): G1"

Start pressure (启动压力): 1.0Bar/1.5Bar/2.2Bar/1.0-2.5Bar/2.5-4.0Bar

Maximum working pressure (最大工作压力): 10Bar

Protection grade (保护等级): IP65

Maximum operating temperature (最高工作温度): 60°C/100°C

Color (颜色): optional (可选配)

Cable (电线): optional (可选配)

包装尺寸 / PACKING SIZE

Model 型号	Packing 包装	Size 尺寸	G.W/N.W. 毛/净重(KGS)	Loading 装柜量
PS06-1A	20pcs/ctn	54 x 41.5 x 22.5	14.2/13.2	40ft HQ: 26800pcs, 20ft: 11000
PS06-1B	20pcs/ctn	54 x 41.5 x 22.5	14.2/13.2	40ft HQ: 26800pcs, 20ft: 11000

HEIGHT ↑↓	PUMP PRESSURE 🔧	START PRESSURE 📊	🔌
10m	2,5Bar	1,5Bar	🔌
20m	4Bar	2,3Bar	🔌
30m	5Bar	3,5Bar	🔌
40m	6Bar	4,5Bar	🔌

PRESSURE SWITCH | PS-07

WWW.CHINA-SOYUE.COM

SOYUE 索月
EXPERT IN PRESSURE CONTROL

PS-07 AUTOMATIC PUMP CONTROL

产品参数 / TECHNICAL DATA

Rated voltage (额定电压): 110V/220V/85V-285V

Maximum current (最大电流): 10A/20A/30A

Frequency (频率): 50/60Hz

Maximum power (最大功率): 1.1kw/1.8kw/2.2kw

Interface thread (接口螺纹): G1"

Start pressure (启动压力): 1.0Bar-5.5Bar

Maximum working pressure (最大工作压力): 10Bar

Protection grade (保护等级): IP65

Maximum operating temperature (最高工作温度): 60°C/100°C

Color (颜色): optional (可选配)

Cable (电线): optional (可选配)

包装尺寸 / PACKING SIZE

Model 型号	Packing 包装	Size 尺寸	G.W/N.W. 毛/净重(KGS)	Loading 装柜量
PS07	12pcs/ctn	47 x 28.5 x 35	11.5/10.5	40ft HQ: 17200pcs, 20ft: 7000



PS07



PS07



PS07



PS07

HEIGHT ↑↓	PUMP PRESSURE 🔧	START PRESSURE 📏	🔌
10m	2,5Bar	1,5Bar	🔌
20m	4Bar	2,3Bar	🔌
30m	5Bar	3,5Bar	🔌
40m	6Bar	4,5Bar	🔌

FLOAT SWITCH

WWW.CHINA-SOYUE.COM

SOYUE 索月
EXPERT IN PRESSURE CONTROL



FS01

FS02

FS03

FS04



BW01



BW02

ILLUSTRATION FOR COUNTERWEIGHT INSTALLATION:

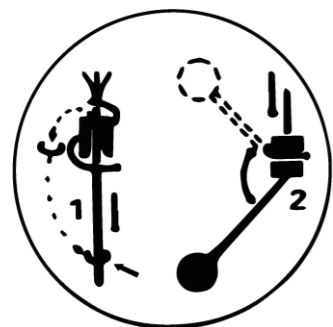

Peel the plastic ring off the counterweight before installation and set the ring around the cable, then insert and fix it with moderate pressure at the fixing end.

FLOAT SWITCH

产品参数 / TECHNICAL DATA

Rated voltage (额定电压): 110V/220V

Frequency (频率): 50/60Hz

Rated current(额定电流): 16 (4) A

Protection grade(保护等级): IP68

Maximum operating temperature(最高工作温度): 55°C

Color(颜色): optional(可选配)

Cable(电线): optional(可选配)

描述 / DESCRIPTIONS

1. 自动补水模式

Auto-fill-water modes

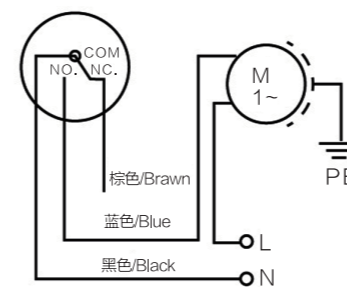

将控制器的蓝色线与水泵相连，黑色线与零线相连，棕色线不接或绝缘。

connect the control's blue line to electric pump, black line is connected to zero-line, black, brown line can not be connected and should be insulated.

2. 自动排水模式

Auto-drainage-and-lack-water protection modes

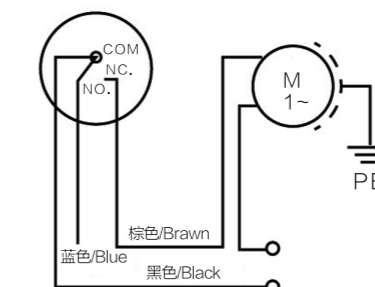

将控制器的棕色线与水泵相连，黑色线与零线相连，蓝色线不接或绝缘。

connect the control's brown line to electric pump, the black line is connected to zero-line, the blue line can not be connected and should be insulated.

3. 补水排水自动切换模式

Fill-water and drainage auto-switch modes

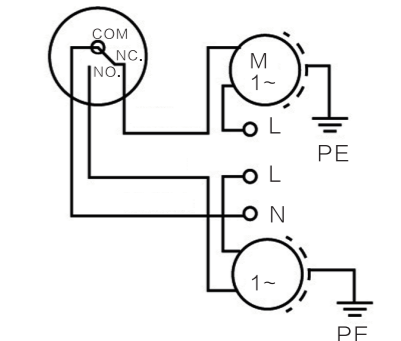

补水排空自动切换方式的电气接线图是自动补水、自动排空两种模式的综合运用。

the chart is fill-water and drainage auto-switch mode, this electric connection chart synthesize by automatic fill-water and auto-drainage.

SPARE PARTS

WWW.CHINA-SOYUE.COM

SOYUE 索月
EXPERT IN PRESSURE CONTROL

Quick connector



Circuit board

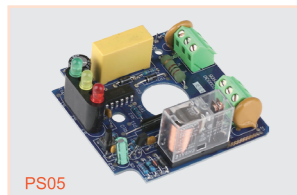
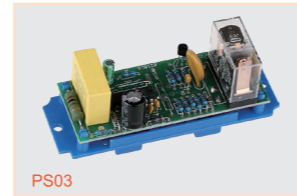
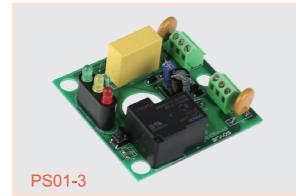

Copper connector



EPDM



SOYUE 索月
EXPERT IN PRESSURE CONTROL

SPARE PARTS

WWW.CHINA-SOYUE.COM

Mechanical switch

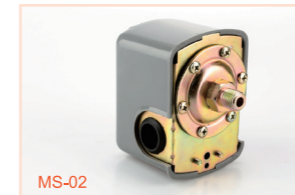

Pressure meter



Socket and plug

